

# 1964

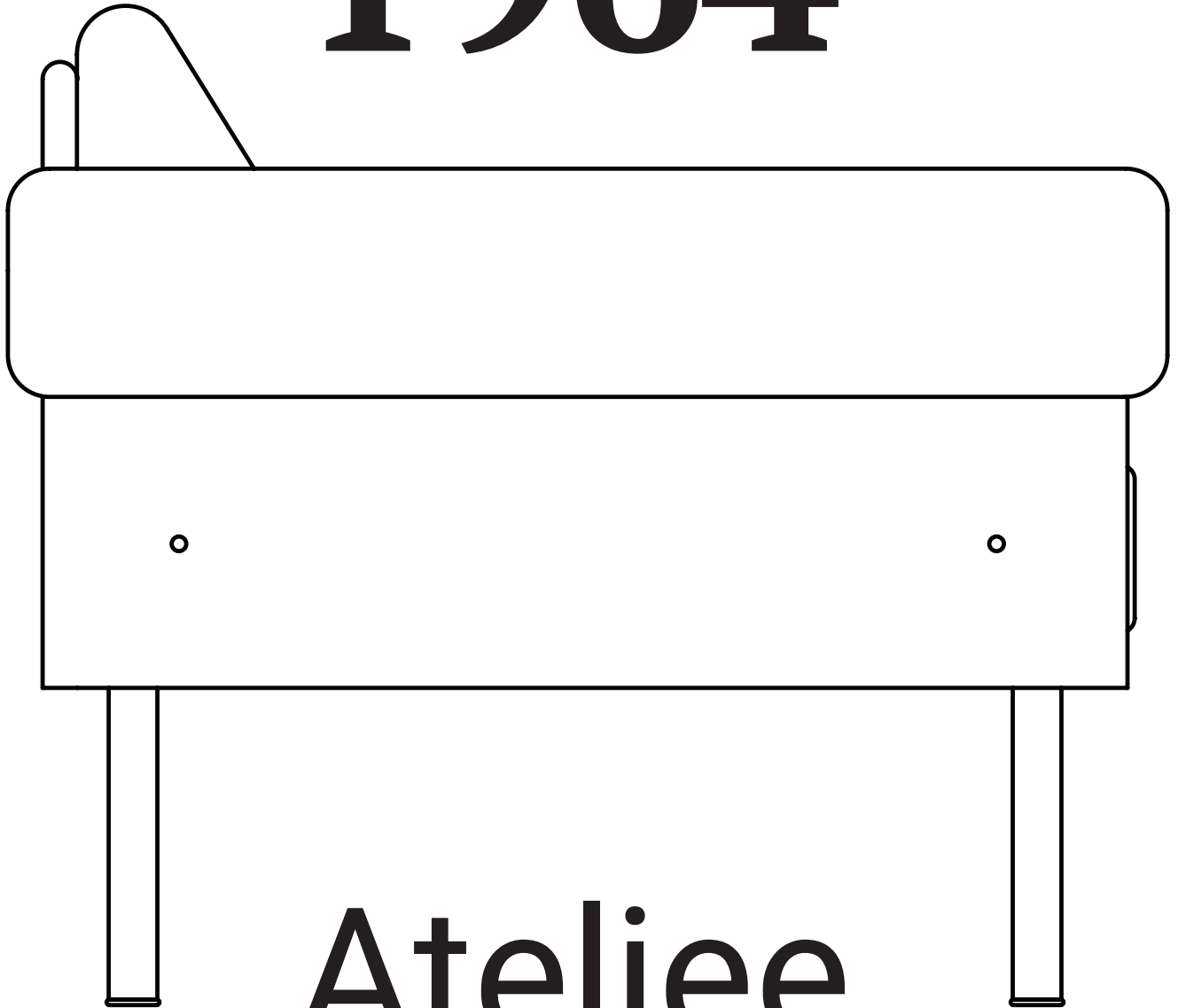

SUMMER 2022

LOOKBOOK

# Ateljee

“this chair  
will serve for  
generations”



-Yrjö Kukkapuro

# YRJÖ KUKKAPURO

## The Man Behind Iconic Finnish Designs



Ateljee, 1964



Karuselli, 1965



Remmi, 1969

Yrjö Kukkapuro is one of our most internationally renowned and award-winning furniture designers and one of the most significant modernists in Finnish furniture design. The design work of Kukkapuro is based on both aesthetic and functional innovation, user experience and ergonomics.

During his extraordinarily long career of over 60 years, Yrjö Kukkapuro has created modernistic furniture for the era, which time has proven to be modern classics. Objects designed by Kukkapuro are on display in permanent exhibitions at the Museum of Modern Art in New York and the Victoria and Albert Museum in London.

Kukkapuro's career in design spans the years from mid-50's to the present. These decades have provided several collections whose design language is always coherent and functional.

During his extraordinarily long career of over 60 years, Yrjö Kukkapuro has created modernistic furniture for the era, which time has proven to be **modern classics.**

By the year 1963 Yrjö Kukkapuro was a 30-year-old, award-winning designer. There were expectations accumulating regarding the continuation for his first solo exhibition. By that time, his designs were mainly aimed for public spaces so to widen the scope of design Kukkapuro felt that he should create something that would also suit the home environment.

He began to work on an idea which as a source of inspiration used a popular finish bed called Heteka. The bed was lightweight and had an extremely durable metal construction. Similarly in Kukkapuro's design a tubular metal body formed a frame into which rubber straps were tensioned. This formed a lattice-like base on which comfortable foam seat cushions and triangular backrest cushions were placed. The back and the armrests were plywood sheets that gave a distinct and somewhat everyday visual appearance.



The Ateljee product line was first presented at the Cologne trade fair in 1964 and was an immediate international success. The popularity of the Ateljee series is due to its versatility, it adapts to all interiors and styles, and can be brought to new decades with new frame materials and upholstery colors and qualities. Due to its modular structure, the Ateljee is expandable from a seat to a sofa of any required length. The modularity also means that the Ateljee is durable and repairable in all respects.

The Ateljee has been selected for the Victoria & Albert Museum Collections in London and the MoMa Museum Collections in New York City.





Ateljee series is a Key Flag product.  
Key Flag Symbol is a registered collective mark.  
It demonstrates that the product has been  
manufactured in Finland.

MATERIAL AND COLOR SELECTION EXAMPLES FOR ATELJEE SERIES



With headrest



# Ateljee Chair



Ateljee series meets the European Standard EN 16139:2013/AC:2013 Furniture – strength, durability and safety – requirements for non-domestic seating.

MATERIAL AND COLOR SELECTION EXAMPLES FOR ATELJEE SERIES



With headrest



Ateljee for Two



MATERIAL AND COLOR SELECTION EXAMPLES FOR ATELJEE SERIES



# Ateljée for Three

# Dimensions

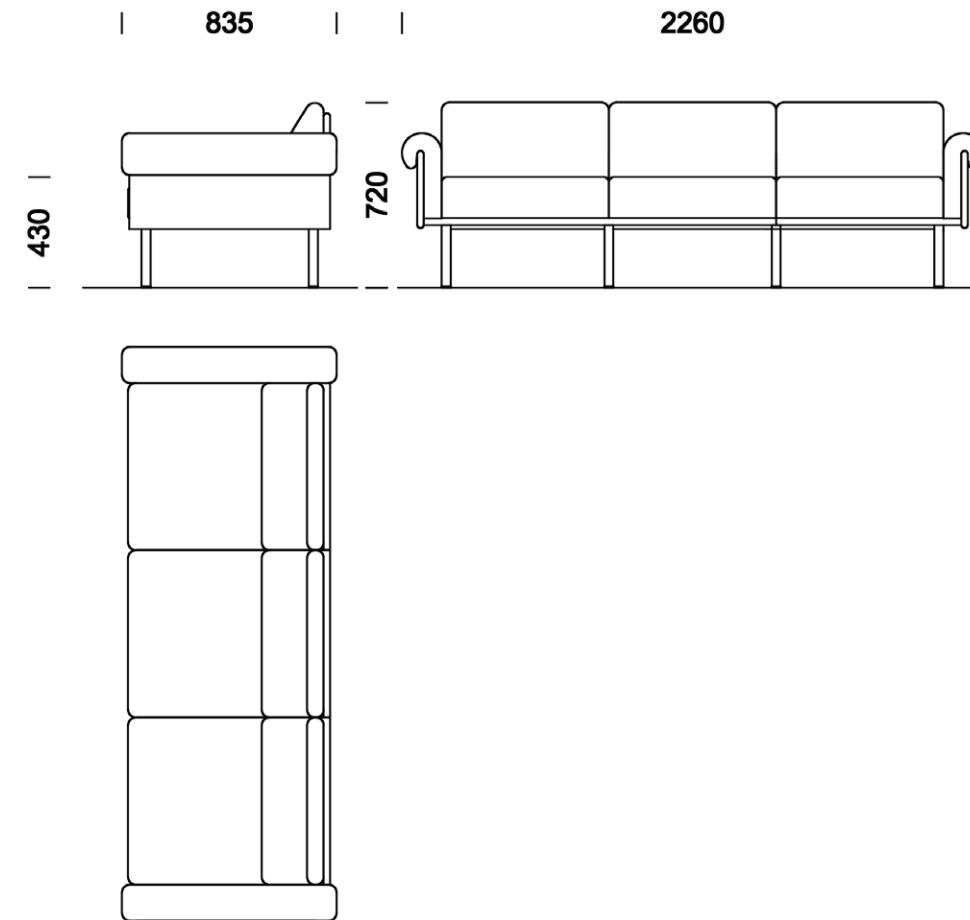
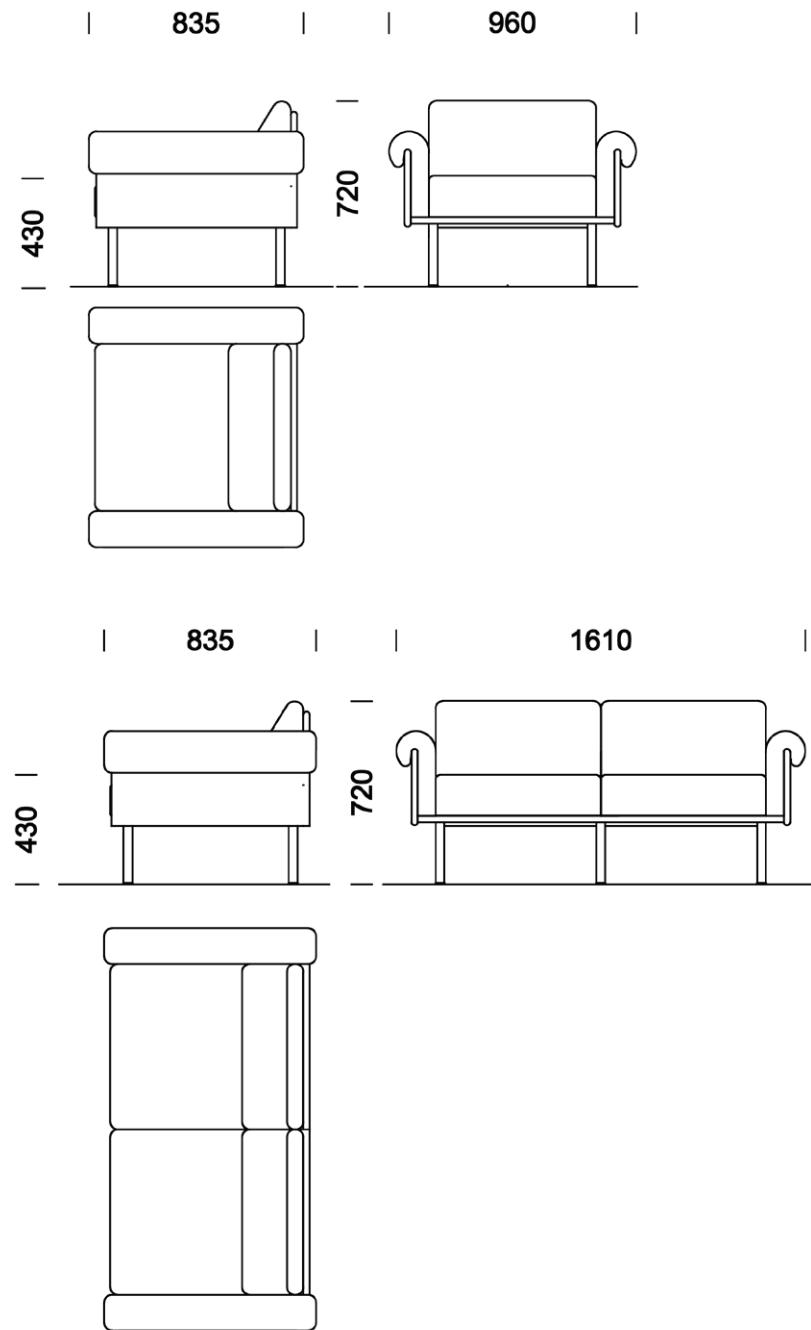

## MATERIAL AND COLOR SELECTION FOR ATELJEE SERIES

### UPHOLSTERY

Black leather  
Brown leather  
White leather

Artek Zebra-fabric

### SIDE PANELS

Black  
White

Oak  
Birch  
Walnut

### FRAME

Black  
White



### HEADREST

The headrest is optional and can be easily installed to the backrest.

Meticulous care has been taken to make sure that the parts are interchangeable with the original parts now and in the future.







In matters relating to Yrjö Kukkapuro collection  
please contact customer service at:  
[info@yrjokukkapuro.com](mailto:info@yrjokukkapuro.com)



**YRJÖ KUKKAPURO**

[yrjokukkapuro.com](http://yrjokukkapuro.com)